

OILGEAR TYPE 4 INCH "PL" LIQUID METER WITH 6 INCH CONNECTORS - PL 40A-1B1A-60 WITH NDH READOUT

SERVICE INSTRUCTIONS LD02021-006

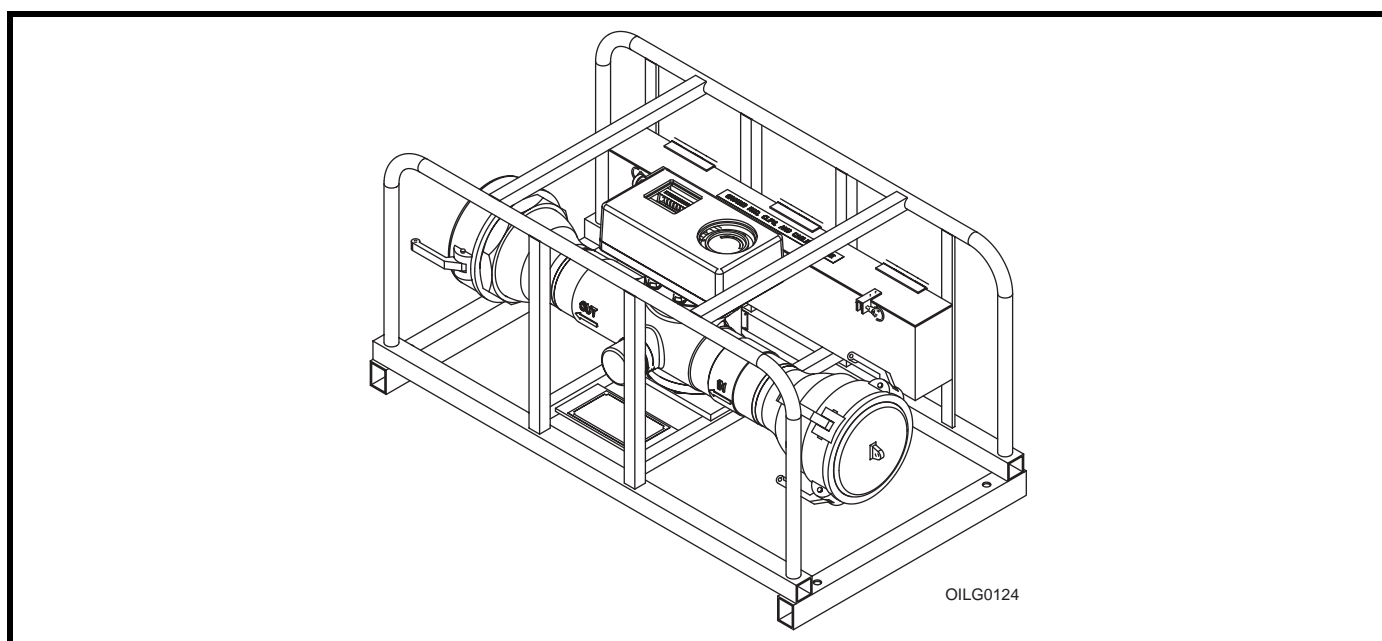

Figure 1. 4 Inch "PL" Liquid Meter with 6 Inch Connectors

The European Union, Directive 97/23/EC (29 May 1997) on the approximation of the laws of the Member States concerning Pressure Equipment has been considered during the design, manufacture, and testing of this meter. This instruction manual is provided to guide the installation and use of the meter. The Oilgear Company is responsible for the application of sound engineering practices of The United States of America and for the Conformity of Europe (CE).

Safety First

Read and understand this entire instruction sheet before repairing, or adjusting your Oilgear product.

Those who use and maintain this equipment must be thoroughly trained and familiar with the product. If incorrectly used or maintained, this product and its equipment can cause severe injury.

SAFETY SYMBOLS

The following signal words are used in this instruction sheet to identify areas of concern where your safety may be involved. Carefully read the text and observe any instructions provided to ensure your safety.

DANGER

THIS SIGNAL WORD INDICATES AN IMMEDIATELY HAZARDOUS SITUATION WHICH, IF NOT AVOIDED, WILL RESULT IN DEATH OR SERIOUS INJURY.

WARNING

This signal word indicates a potentially hazardous situation which, if not avoided, could result in death or serious injury.

CAUTION

This signal word indicates that a potentially hazardous situation exists which, if not avoided, may result in damage to equipment or minor personal injury.

NOTE

While not directly relevant to the topic being discussed, the NOTE is used to emphasize information provided, or provide additional information which may be of benefit.

WARNING

This service information is designed for the maintenance of your Oilgear product. It contains the information on the correct procedures determined by Oilgear for the safe manner of servicing. Always keep this instruction sheet in a location where it is readily available for the persons who use and maintain the product. Additional copies of this instruction sheet are available through the Oilgear Company. Or visit our website: www.oilgear.com. Please contact us if you have any questions regarding the information in this instruction bulletin.

NOTE

The cleanliness of working on this meter or the system is extremely important to the safety and reliability of the meter and the system. Always make sure the fittings are clean on the outside before removing them from their connections, are capped and plugged when removed and placed in a clean rag or container until they are reinstalled.

WARNING

Some service operations may require special tools or equipment. If you require information on these items, please contact Oilgear before attempting these repairs and service operations.

WARNING

Read, understand, and follow the safety guidelines, dangers, and warnings contained in this instruction sheet to promote reliable operation and prevent serious personal injury.

DANGER

GASOLINE AND OTHER FUELS ARE EXTREMELY FLAMMABLE AND HIGHLY EXPLOSIVE UNDER CERTAIN CONDITIONS.

STOP THE ENGINE OF THE FUELED VEHICLE BEFORE FUELING. FUEL OUTDOORS, NEVER INDOORS OR IN A CONFINED AREA.

DO NOT SMOKE, ALLOW OPEN FLAME OR SPARKS NEARBY WHEN FUELING.

GROUND THE FUELING EQUIPMENT BEFORE BEGINNING FUELING PROCEDURE. DO NOT CONNECT OR DISCONNECT THE GROUND DURING FUELING. DO NOT USE ANY DEVICES IN BETWEEN THE FUEL DELIVERY FUELED VEHICLE THAT IS NOT GROUNDED.

MAKE SURE ALL CONTAINERS FOR FLAMMABLE AND COMBUSTIBLE LIQUIDS ARE CLEARLY AND CORRECTLY MARKED.

READ AND UNDERSTAND ALL SAFETY PRECAUTIONS FOR THE VEHICLES AND EQUIPMENT BEING FUELED.

⚠ DANGER ⚠

DO NOT STORE GASOLINE OF ANY HIGH COMBUSTIBLE FUELS INSIDE OR TRANSPORT IN ANY OTHER LOCATIONS EXCEPT FOR THOSE DESIGNED OR DESIGNATED FOR THIS PURPOSE.

KEEP ALL EQUIPMENT IN GOOD CONDITION. CHECK FOR LEAKS, DETERIORATION OR DAMAGE. MAKE NECESSARY REPAIRS OR REPLACE FAULTY COMPONENTS IMMEDIATELY.

IF FUEL IS SPILLED ON YOUR CLOTHING, KEEP AWAY FROM ANY IGNITION SOURCE, AND ALLOW THE CLOTHING TO DRY. IF THE QUANTITY IS IN EXCESS, REMOVE THE CLOTHING.

AVOID FUEL CONTACT WITH YOUR SKIN AND FACE, WASH THE FUEL FROM YOUR SKIN IMMEDIATELY.

AVOID PROLONGED EXPOSURE AND INHALATION TO FUEL VAPORS.

⚠ WARNING

DO NOT attempt to service this machinery in an environment where safety regulations are not established and in place.

⚠ WARNING

DO NOT operate the meter or system if a leak is present. Serious injury may result.

⚠ WARNING

Some systems operate under very high pressure. Fluid escaping from a pressurized system can penetrate unprotected body tissue. DO NOT inspect for leaks with bare hands or other exposed body parts. As a minimum, wear leather gloves prior to inspecting for leaks and use cardboard or wood. If leaks are present, relieve pressure and allow system to cool prior to servicing. If injured by escaping fluid, contact a physician immediately. Serious complications may arise if not treated immediately. If you have questions regarding inspecting for leaks, please contact Oilgear prior to servicing.

⚠ WARNING

The system must be inspected on a daily basis for leaks or hidden damage before the system is put into service. Replace damaged piping or piping you suspect may be damaged before the system is returned to service! Failure to properly inspect and maintain the system may result in serious injury.

⚠ WARNING

Some systems are hot. DO NOT TOUCH! Serious personal injury may result from hot fluids. When you have completed working on the system, thoroughly clean any spilled fluids from the equipment. Do not spill any fluids on the ground. Clean any fluids from your skin as soon as you have completed maintenance and repairs. Dispose of expelled fluids and system filters as required by law.

⚠ WARNING

Use correct piping, fittings, and adapters with the correct SAE rating when replacing them to prevent possible serious injury. Always replace piping, fittings, and adapters with replacements that have a proper, suitable, working pressure rating. Replacement piping must be of the correct length and must comply with the piping manufacturer's and Oilgear's installation guidelines and recommendations.

⚠ WARNING

All pressure must be relieved from the system prior to removing any components from the system. To relieve the pressure from the system, turn off the pump. Failure to comply can result in serious injury. If you have any questions concerning relieving the pressure from the system, please contact Oilgear.

Safety First

WARNING

Some system components can be heavy. Use caution while lifting these components. Serious personal injury can be avoided with proper handling of the components.

WARNING

Please contact Oilgear if you require assistance, when performing test procedures, use the proper gauges. Installing an incorrect test gauge could result in serious injury if the gauge fails. Use properly rated piping and connections to allow the test gauge to be read away from moving parts and functions.

WARNING

Increasing pressure beyond the recommendations may result in serious damage to the meter and system or serious personal injury and may void the Oilgear Warranty. If you have questions concerning pressures or testing procedures, please contact Oilgear before attempting the test procedures or making adjustments.

WARNING

An Oilgear meter must not be modified in any way without authorization from Oilgear. Modifications may not comply with safety standards, including ANSI safety standards, and may result in serious personal injury. Please contact Oilgear if you require assistance.

WARNING

Any Oilgear meter safety decals must be replaced anytime they are damaged, missing, or cannot be read clearly. Failure to have proper decals in place can result in serious injury or death. (If you require safety decals, please contact Oilgear for replacement safety decals, at no charge.)

WARNING

Wear the proper protective clothing when operating, servicing or maintaining the system or the Oilgear meter. Wear the correct protective gear, safety glasses, gloves, and safety shoes. Serious injury can result without proper protective gear.

WARNING

Make sure to keep hands and feet and other parts of your body clear of revolving or moving parts. Failure to comply can cause serious injury.

WARNING

DO NOT wear watches, rings, or jewelry while working with electrical and mechanical equipment. These items can be hazardous and can cause serious and painful injuries if they come into contact with electrical wires or moving parts.

FUEL SERVICE PERSONNEL

Fuel servicing personnel must be trained in the safe operation of the fueling equipment.

Guidelines:

1. No smoking within 50 feet of fueling equipment or during fueling.
2. Fuel outside only. Never fuel inside or in a confined area.
3. Read and understand all safety information on fueling the vehicles being fueled.
4. Fueling must be done with no passengers on board or in accordance with the provisions of Rapid Refueling.
5. The fueled vehicle and fueling equipment must be grounded to dissipate static electricity.
6. Grounding must be done before fueling and not connected or disconnected during fueling.
7. Fueling equipment must be kept 20 feet (6 meters) or beyond the fueled vehicle.
8. Trained personnel should direct the fuel servicing vehicle's approach and departure.
9. Personnel must not carry lighters, matches, or igniting devices or equipment during fueling.
10. Only qualified / designated personnel properly trained in fueling operations must operate the fueling equipment.
11. Persons not directly involved with the refueling operation must be kept clear of the refueling area.
12. All doors, windows, access points and ventilation systems that could allow entry of vapors into the interior of the vehicle, near the vicinity of the fuel inlet ports, must be closed and kept closed during fueling operations.
13. Fumes or vapors must be adequately vented from the vehicle during fueling operations.
14. Fuel must be dispensed from approved nozzles.
15. At the first sight of lightning or static storms in the area, fueling operations should be suspended.
16. If a spill occurs, fueling must stop, and cleanup and emergency measures taken, if necessary.
17. Never store fuel in food or drink containers.
18. Check for leaks or deterioration in fuel storage and delivery equipment.
19. Know the type of fuel you are working with:
 - 100 octane aviation gasoline (avgas) is green.
 - 100 octane low lead avgas is blue.
 - Jet fuel is usually clear, but sometimes it is a very light yellow color.

RAPID REFUELING

Rapid refueling is a refueling operation conducted while engines are running. Rapid fueling should be avoided, and must be done in safe, carefully controlled conditions by trained personnel, and all personnel must adhere strictly to safe fueling practices.

Reciprocating engine-powered aircraft fueled with avgas SHOULD NEVER be rapid refueled because gasoline is highly flammable.

All personnel and vehicle operators involved in rapid refueling must be trained in safe techniques and procedures before conducting such operations. Initial and recurrent ground training on rapid refueling must be included in the training program and each person's duties and responsibilities must be specified. The training must include all of the engine manufacturer's specific recommendations and/or procedures regarding rapid refueling, checking fluid levels and adding fluids, cool down times, and other important items or topics for these procedures.

Guidelines:

1. Follow all the guidelines for normal fueling.
2. Observe proper grounding of equipment.
3. Follow operation of fuel vehicles and fuel delivery equipment.
4. Communicate with vehicle operators and others.
5. Follow fuel spill procedures and emergency measures.
6. Be alert to personal injury response.
7. Know fuels and quality control procedures.
8. Know which turbine-powered vehicles fueled with Jet A or Jet A-1 fuels can be fueled while an onboard engine is running.
9. A certified / qualified operator must be at the fueled vehicle controls during the entire fuel servicing process.
10. No passengers should be onboard and must be positioned in a safe location before beginning the rapid refueling process. If passengers remain onboard during fuel servicing, at least one person other than the certificated / qualified operator, must be trained in emergency evacuation procedures. The operator should establish specific procedures covering emergency evacuation under such circumstances.
11. Only qualified / designated personnel properly trained in rapid refueling operations must operate the fueling equipment.

12. Persons not directly involved with the refueling operation should be kept clear of the refueling area.

CONSTRUCTION AND OPERATION

GENERAL INFORMATION

Oilgear type PL liquid meters are precision measuring instruments which operate on a simple principle. Their rugged construction must still be given care in handling and storage. Do not drop or allow heavy objects to fall on it. Meters can be damaged when transporting. These meters are designed for transporting with their tubular frame skid. These framed meters are easy to handle and provide a degree of protection should the meter inadvertently be dropped. The maximum service and accuracy are built into each of these meters. We recommended following the general policies outlined below.

- DO NOT accept a shipment that shows evidence of mishandling in transit without making an immediate inspection for damage to the meter.

- File a claim with the carrier if damage is indicated and notify The Oilgear Company.
- Save the packing list with all your maintenance records. It contains the following information:
 - Meter calibration.
 - Readout gear reduction and/or pulse rate.
 - Serial number.

Since damage to internal parts can occur without obvious external evidence, check all new meters for free rotation soon after arrival. Refer to **INSTALLATION**.

When a meter is not to be tested or installed immediately, store it in a clean location and protect against damage and the elements.

DO NOT interchange readouts to different meters without matching the calibration numbers of each unit, or without first contacting The Oilgear Company. If any serious trouble occurs during installation or initial operation of a new unit, contact The Oilgear Company. DO NOT attempt repairs or adjustments, this can void the warranty.

When contacting The Oilgear Company with a problem, always give the meter model and serial number, location, type of fluid being used and a brief outline of the problem.

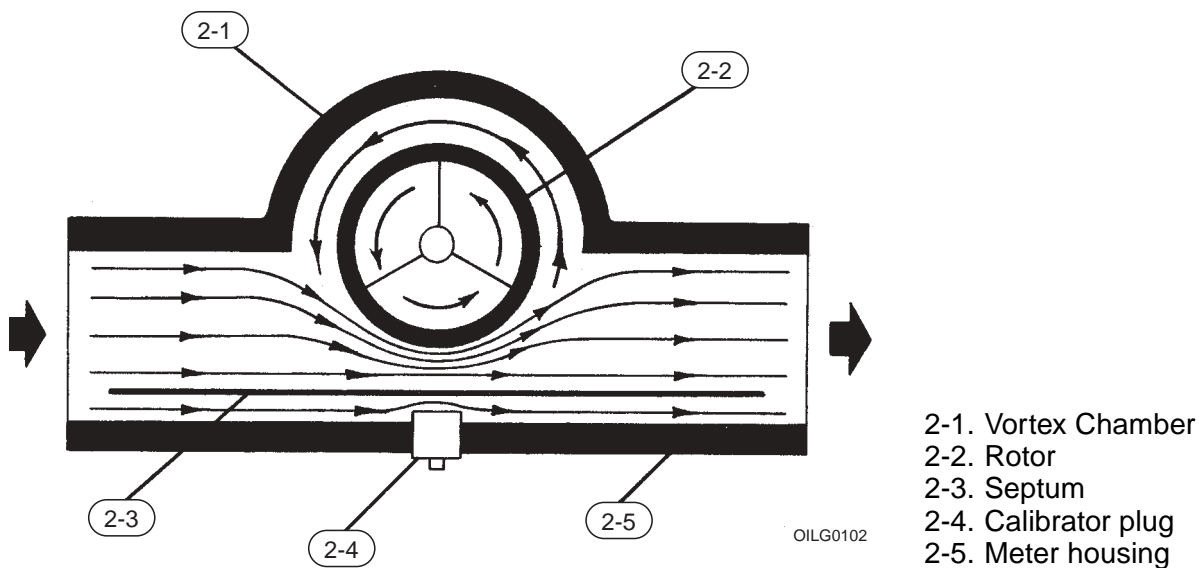

Figure 2. Cut-a-way drawing illustrating basic construction and operating principle.

DESCRIPTION AND CHARACTERISTICS

Figure 2. The Oilgear type PL liquid meter consists of a body with an offset chamber and a rotor mounted transverse to the flow stream.

When liquid flows through the meter, the rotor is driven by the flow stream, combining the effects of a Pelton wheel and a centrifugal flow turbine. This combination gives a rotor speed "proportional" to the flow "velocity" passing through the rotor chamber, over a wide range of flow rates. A magnetic coupling, transfers the rotor movement to a readout device.

The meter body is divided by a septum or thin plate. A calibration plug is located in the meter beneath the septum. Moving the plug within the section beneath the septum, changes the cross sectional area and causes more or less liquid to flow through the measuring section. The calibration plug then causes a proportional increase or decrease in rotor speed for the same total flow through the meter. Since meter registration is directly related to rotor speed, adjustment of the plug position readily changes the meter registration.

CONSTRUCTION

Oilgear type PL liquid meters are manufactured in different sizes. They are offered for a variety of pipe sizes with selections of materials and bearing types. They are intended for handling clear liquid at flow rates, pressures, and temperatures within their nameplate ratings.

The construction of an Oilgear type PL liquid meter is described by its model number. Refer to PV Flow Meter and Readout Specifications bulletin 90901 for complete ordering and selection information.

LUBRICATION

The bearings of the Oilgear type PL liquid meters are lubricated by the liquid being metered. If the meter is handling contaminated liquids or solutions which tend to precipitate solids, periodically flush the meter with clean liquid. Flushing is important if the meter will stand idle while filled with solutions which can precipitate solids.

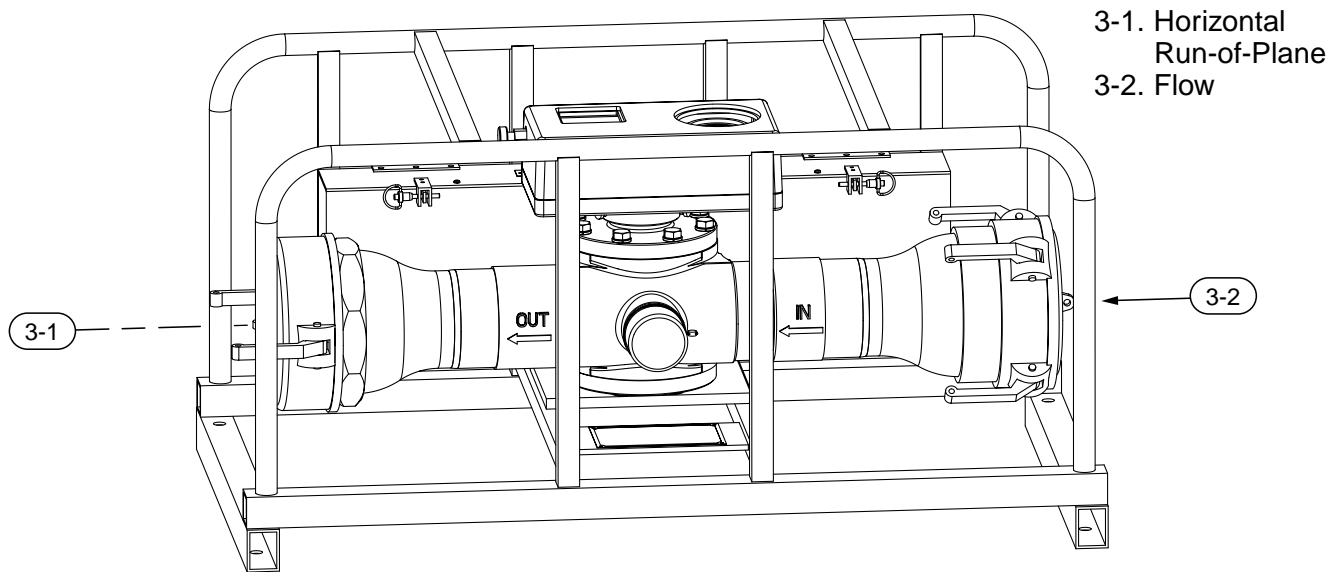

3-1. Horizontal
Run-of-Plane
3-2. Flow

OILG0137

Figure 3. Oilgear type PL liquid meter correctly installed with the rotor-cage shaft properly aligned to the horizontal run-of-line. Single hub meter with "B" rotation side shown (84004).

INSTALLATION

METER MOUNTING

Figure 3. The Oilgear type PL liquid meter looks like a short section of pipe with a rotor and rotor chamber offset, and is perpendicular to the “flow axis.”

CAUTION

The PL liquid meter is self-contained and mobile. If it is mounted, it must be mounted on a horizontal run-of-line and the calibration plug facing the side.

The PL liquid meter must have the readout mounting hub on top of the meter.

NOTE *DO NOT install the meter with the readout mounting hub facing the side or down. When the PL liquid meter is used or mounted, it must be in the plane as shown in Figure 4. If your readout device has totalizing counters and cannot be readily viewed, contact The Oilgear Company.*

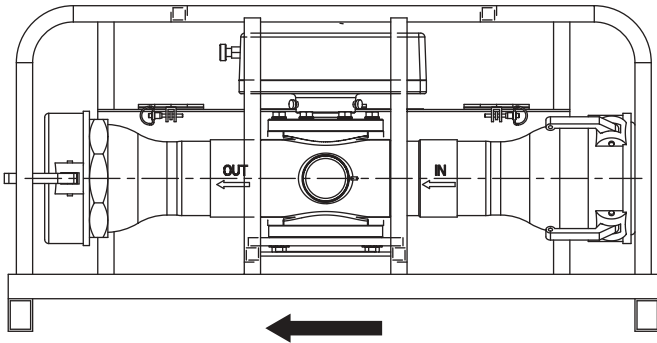

OILG0129

Figure 4. Flow direction when facing the readout (meter turning clockwise).

Figure 4. Before installing the PL liquid meter, verify the direction of flow as designated by the arrows cast into the meter. If the meter is installed backwards, it will register only about 60% of the actual flow. If the first letter is “B”, this designates flow will be right to left when facing the readout hub.

INSTALLATION CHECK LIST

CAUTION

Oilgear type PL liquid meters must be installed in accordance with accepted engineering practices for the best performance.

The following checklist provides a guide to proper installation practice.

WARNING

All operations must be performed by trained personnel.

The PL liquid meter is designed to be mobile and easy to handle. If necessary, seek assistance from others and use a hoist and/or proper lifting techniques to prevent personal injury.

DO NOT enter under any supported equipment unless it is fully supported or blocked. Failure to follow this procedure can result in serious injury or death.

LIFTING - Make sure all lifting equipment is adequate, and certified for use. Use all the lifting facilities provided. Vertical lifts must be done so there are no uncontrolled out of level movements. Some items may need a sling to lift or turn. To do this, make sure approved safety methods are used.

Weight - 100 lbs (45,4 kg) approximately.

NOTE *DO NOT overload lifting equipment. Weight is a single unit without additions.*

Flow control devices and check valves - must be down stream of the meter.

Pressure - Do not exceed the pressure shown on the nameplate for the fluid being metered.

Piping alignment - Avoid misaligning piping.

Installing and support piping - Install and support piping in accordance with local piping codes.

Meter protection - Protect the meter from test or transient pressures in excess of nameplate rating.

- Protect the meter from physical damage.
- Protect the meter from damage by freezing of the liquid.

Meter position - Locate the meter in a position that is not susceptible to dirt or sediment collection.

Piping configurations - Observe the recommended upstream and downstream piping configurations to avoid swirl and turbulence errors.

Throttling of liquids - Avoid upstream throttling of liquids flowing at, or near their vapor pressure to avoid flashing from liquid to vapor.

Back pressure - Maintain sufficient back pressure on the downstream side to prevent flashing of liquids within the meter body.

Calibration code - Match the calibration code on readout to that on the meter.

Mounting meter - Meter must be mounted with rotor-cage shaft in vertical position.

- Meter must be mounted with the calibration plug facing the side.

Closure plugs - Remove all temporary closure plugs from pipes and other equipment just prior to joining together.

DO NOT - Install a meter on the suction side of a pump.

- Use meter as a step.
- Allow for conditions which may induce hydraulic shock.
- Weld on meter.

Verify rotor rotation - Verify rotor for free rotation by directing a controlled flow of compressed air in inlet. Do not over-speed.

Shut-off valves - Use full flow shut-off valves with unrestricted flow in the operating position.

Alignment -

Piping Distortions - Do not allow for any distortion of piping when aligning joint assembly. Any distortion will introduce strain in the meter.

PIPING CONFIGURATIONS

Recognized authorities have established under most conditions of fluid flow, a minimum length of twenty (20) pipe diameters upstream and five (5) pipe diameters downstream of meter bore piping will result in measurement free of the influences of swirl, distortions or other unsymmetrical patterns.

NOTE

The cleanliness of the pipe and connections is extremely important to the safety and reliability of the meter and the system. Clean pipe must be used. Always make sure the pipes and fittings are clean before installing them. Keep all connections capped and plugged and on a clean surface. Inspect for foreign objects which could become lodged in the meter or system. Pipe schedule should be adequate for maximum meter operating pressure. The installation of swirl producing obstructions upstream of the meter may create measuring inaccuracies unless precautions are taken.

We recommend using straightening vanes if the minimum setting length of twenty pipe diameters cannot be accommodated.

READOUTS

Readouts are identified with the meter serial number when the meter and readout are purchased as a unit. When they are sold separately, the meter and readout are individually identified with separate serial numbers.

Nameplates of meter and readout are stamped with a calibration code (1.20, etc.). The code represents the number of rotor revolutions calibrated per gallon for the meter.

When using a meter and readout that were not purchased as a unit, be sure the calibration code on the readout matches the calibration code on the meter.

NOTE

DO NOT interchange readouts to different meters without matching calibration numbers of each unit or without first contacting The Oilgear Company.

Contact The Oilgear Company to obtain calibration codes for units manufactured on or before April 30, 1984 and are not stamped. Serial numbers of meters and readouts will be required to identify your meter.

READOUT MOUNTING - GENERAL

Check the readout device model code for "B" rotation as designated by the first letter in the second group of letters and numbers. For single readout drive meters, use "B" readouts with "B" meters.

READOUT MOUNTING TO THE METER

Readouts are mounted to the meter. The material of the sleeve was selected to eliminate galvanic corrosion between the meter and readout and for strength and durability.

Do not over-tighten the three point set-screws that secure the readout onto the mounting ring groove on the meter housing.

CAUTION

Do not exceed 40 in-lbs (4,5 N-m) to torque the three point set-screws. Use only the setscrews and locknuts provided.

Refer to **Figure 5** through **Figure 11** for proper recommended installations practices.

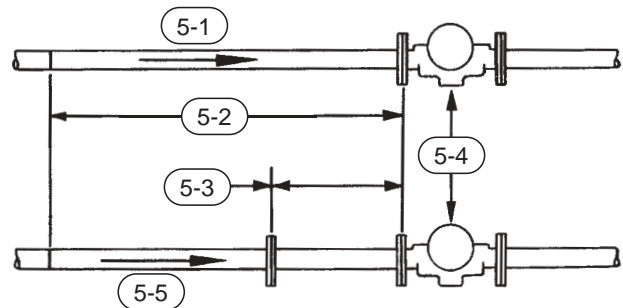

OILG0105

- 5-1. Pipe with same internal diameter as meter.
- 5-2. Adequate setting length.
- 5-3. Five diameters of pipe with same I.D. as meter
- 5-4. Meter
- 5-5. Pipe I.D. > or < meter I.D.

**Figure 5. Normal installation.
No fluid swirl or profile distortion.**

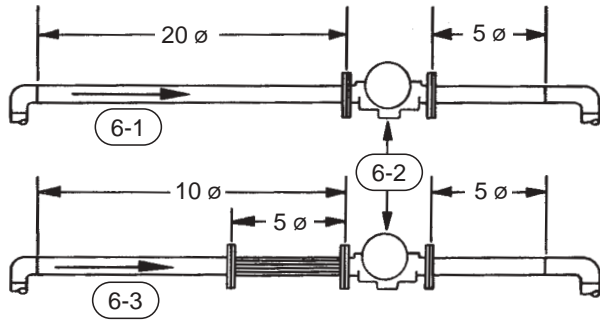

OILG0106

- 6-1. Without flow straightener.
- 6-2. Meter
- 6-3. With flow straightener.

Figure 6. Installation with one elbow upstream.

METER PRESSURE RATING - PSI						
Meter Size	Nominal Diameter (mm)	Meter "Cam-Loc Type" Connection	High Vapor Pressure Group 1 Fluids	High Vapor Pressure Group 2 Fluids	Low Vapor Pressure Group 1 Fluids	Low Vapor Pressure Group 2 Fluids
40	97	60	150	150	150	150

Table 1 - PL40A-1B1A-60 w/ NDH Meter Pressure Rating

European Union, Directive 97/23/EC

The requirement of the European Union, Directive 97/23/EC (29 May, 1997) on the approximation of the laws of the Member States concerning Pressure Equipment has been considered in establishing this pressure rating chart.

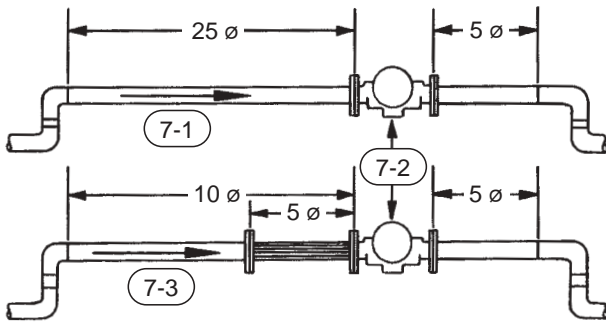

OILG0107

- 7-1. Without flow straightener.
- 7-2. Meter
- 7-3. With flow straightener.

Figure 7. Installation with two elbows preceding meter-single plane.

Low Vapor Pressure Group 2 - Examples:
Hydraulic Oil, Water, HWCF, Water Glycol, Esters.

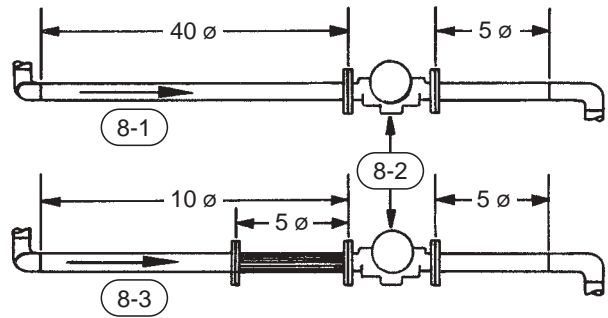

OILG0108

- 8-1. Without flow straightener.
- 8-2. Meter
- 8-3. With flow straightener.

Figure 8. Installation with two elbows preceding meter double plane.

Group 1 Fluids = Explosive, Extremely Flammable, Corrosive, Toxic, Oxidizing.

Group 2 Fluids = Not In Group 1.

High Vapor Pressure Fluids = Those fluids whose vapor pressure at maximum allowable temperature is greater than 0.5 Bar above normal atmospheric pressure. (Evaporate Quickly).

Low Vapor Pressure Fluids = Those fluids whose vapor pressure at maximum allowable temperature is not more than 0.5 Bar above normal atmospheric pressure. (Evaporate Slowly).

High Vapor Pressure Group 1 - Examples: Gasoline, Alcohol, Benzene, Hydrogen.

High Vapor Pressure Group 2 - Examples: Freon, Carbon Tetrachloride, Nitrogen.

Low Vapor Pressure Group 1 - Examples: Acid, Kerosene.

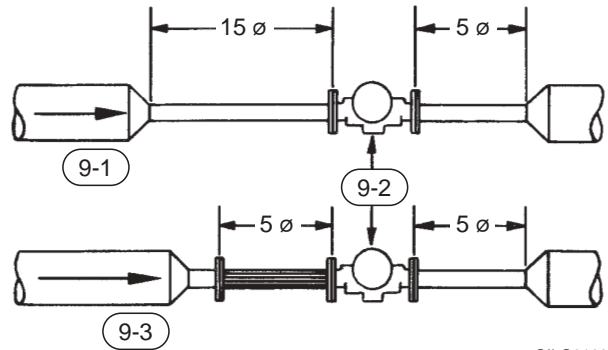

OILG0109

- 9-1. Without flow straightener.
- 9-2. Meter
- 9-3. With flow straightener.

Figure 9. Installation with piping reducers.

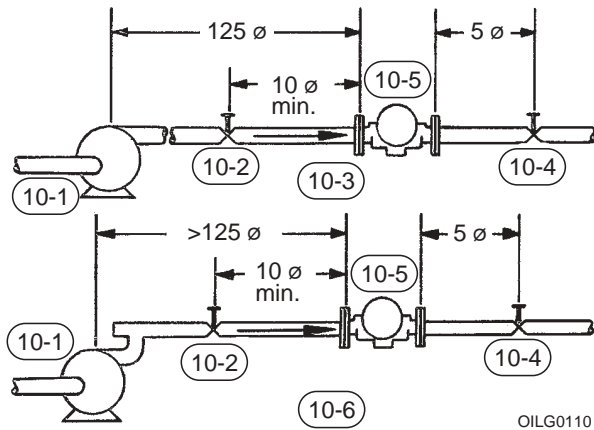

- 10-1. Pump
- 10-2. Shut-off valve.
- 10-3. Normal Installation
- 10-4. Flow control valve.
- 10-5. Meter
- 10-6. Meter installation with less than 125 diameter upstream piping.

Figure 10. Recommended installation- meter and pump configuration.

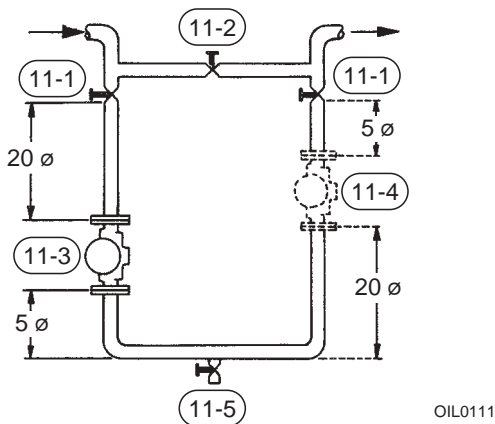

- 11-1. Shut-off valve.
- 11-2. By-pass valve.
- 11-3. Meter
- 11-4. Alternate position.
- 11-5. Drain valve.

Figure 11. "U" piping installation.

PLACING IN SERVICE

After checking the installation for compliance with the installation checklist, the meter is ready for trial under line conditions. Gradually bring the meter to full line flow conditions by opening the downstream control or shut-off valve. Observe meter operation for several minutes, being alert to unusual sounds or vibrations.

! WARNING

The surface of the meter may be hot or cold based on the temperature of the fluid being metered.

The meter design does not take into consideration exposure to fire.

CALIBRATION

NOTE

Each Oilgear type PL liquid meter is calibrated at the factory and the calibration plug cover is sealed. Factory calibration is accomplished using well designed, carefully maintained proving equipment. Meter inaccuracy after installation is frequently the result of improper installation or faulty standards of comparison.

If you suspect the meter registration, first check the installation and make sure all requirements are met. When using a gravimetric proving system, specific gravity and temperature corrections must be carefully considered in computing the volumetric equivalent of the weight of liquid used for testing.

For field proving, the recommended flow standard is a large volumetric calibrated tank or a pipeline type ball piston prover.

The proving tank and volume should be equal to at least the amount passed by the meter in one minute at its maximum rate capacity.

If meter registration is found to be low, first check for a damaged rotor, or worn or damaged bearings before attempting any adjustments.

If meter registration is found to be high, check for upstream obstructions which could result in increased liquid velocity, or an obstruction under the septum or insufficient back pressure, which will also cause over-registration of the meter.

Liquid flowing at or near its vapor pressure may flash and cause over-registration of the meter as will entrained air or gas.

If the meter does not register, check for proper installation of the readout device. If properly installed, check the readout for proper operation by removing and turning by hand.

MAINTENANCE

Meter application will govern the frequency of maintenance. Periodic inspection is recommended as preventive maintenance. Maintain a record of your inspections and findings.

INSPECTION

A general inspection checklist should include at least the following items.

1. Check entire system externally for leaks.
2. Check for obstruction of flow by foreign objects.
3. Remove the cover and inspect the rotor assembly for worn or damaged parts, especially the bearings.
4. Remove the readout and check for proper operation.

DISASSEMBLY

NOTE Refer to **Figures 13 and 14** to assist in location of parts. Numerals in parenthesis in text and figure illustrations correspond to the numerals on the parts lists and drawings.

WARNING

Before attempting disassembly, relieve the pressure from the system and drain the line.

It is not necessary to remove the meter from the line for normal repairs.

NOTE The cleanliness of the repair location is extremely important to the safety and reliability of the meter and the system. Always make sure the work area is clean and parts are clean before reassembly. Keep all connections capped and plugged and on a clean surface.

1. Remove the readout by loosening the three locknuts and set screws and twisting the readout as it is pulled off the mounting ring.
2. Remove the cover screws **(6G)** on the meter cover assembly, then remove the cover assembly (readout side) by pulling straight away from the meter. Protect the rotor during this step.

NOTE The rotor assembly may come out when the cover assembly is removed. If it remains, it should be removed by gently pulling on it. Use care to prevent damage. If the rotor assembly is damaged, it can only be replaced as a complete assembly.

If it is necessary to replace the rotor and shaft assembly and/or bearing inserts, replace all O-rings when they are removed.

NOTE Clean all parts thoroughly and allow them to dry before reassembly. Replace any part that appears worn and/or show signs of fatigue, or if you suspect damage. Apply a suitable O-ring lubricant to all O-rings before installation.

ASSEMBLY

NOTE The procedures for reassembly are basically the reverse of the disassembly. Follow these instructions which describe certain additional procedures that must be followed.

NOTE During reassembly, torque fasteners and plugs to specifications in Table 2. Refer to **Table 2**.

BEARING SLEEVE INSERT REPLACEMENT

NOTE Spacer(s) may be used during assembly. If spacer(s) are used, reinstall them during reassembly.

Front Cover

1. Remove throttle plate **(2A)** and any spacers **(2H)**, if used, by removing screws **(2G)**.
2. Remove front bearing insert **(2C)** from the cavity of the cover **(2D)**.
3. Install new bearing insert **(2C)**.
4. Place throttle plate **(2A)** and any spacers **(2H)** removed on the step of the insert and align mounting holes.
5. Secure front throttle plate with screws **(2G)** for insert retention.

Rear Cover

1. Remove throttle plate **(3A)** and any spacers **(3F)**, if used, by removing screws **(3E)**.
2. Remove rear bearing insert **(3B)** from the cavity of the cover **(3C)**.
3. Install new rear bearing insert **(3B)**.
4. Place throttle plate **(3A)** and any spacers **(3F)** removed, on the step of bearing insert **(3B)**, and align mounting holes.
5. Secure rear throttle plate with screws **(3E)** for insert retention.

SEAL REPLACEMENT

NOTE Apply a suitable O-ring lubricant to all O-rings before assembly and protect the rotor and cover assembly when it is removed. Do not reuse O-rings.

Replacement of Diaphragm O-ring

1. Remove the readout by loosening the three locknuts and set screws and twisting the readout as it is pulled off the mounting ring.
2. Remove the cover screws **(6G)** and washers **(6H)** on the meter cover assembly (readout side), by pulling straight away from the meter. Protect the rotor and cover assembly.
3. Remove screws **(2G)**.
4. Remove throttle plate **(2A)** and any spacers **(2H)**.
5. Remove front bearing insert **(2C)** from the cavity of the front cover **(2D)**.
6. From the readout mounting side, push diaphragm **(2B)** inward until it comes out of the cover.
7. Remove diaphragm O-ring **(2E)** and replace it.
8. Assemble the diaphragm **(2B)** into the cover and make sure it is seated against the bottom of the bearing insert cavity.
9. Install front bearing insert **(2C)** into the cavity of the front cover.
10. Place throttle plate **(2A)** and any spacers **(2H)** removed, on the step of the insert and align mounting holes.

11. Secure front throttle plate with screws **(2G)** for insert retention.

NOTE Use care, when sliding the rotor and shaft assembly **(4)** into the bearing insert cavity.

12. Assemble the meter cover assembly **(2)** to the meter housing **(1)**. Use care when sliding the rotor and shaft assembly **(4)** into the bearing insert **(2C)**.
13. Secure cover assembly with screws **(6G)** and washers **(6H)**.

Replacement of Front Cover O-ring

1. Remove the readout by loosening the three locknuts and set screws and twisting the readout as it is pulled off the mounting ring.
2. Remove the cover screws **(6G)** and washers **(6H)** on the meter cover assembly (readout side) and pull cover assembly straight away from the meter. Protect the rotor and cover assembly.
3. Remove O-ring **(2F)** and replace it.
4. Assemble the meter cover assembly **(2)** to the meter housing **(1)**. Use care when sliding the rotor and shaft assembly **(4)** into the bearing insert **(2C)**.
5. Secure cover assembly with screws **(6G)** and washers **(6H)**.

Replacement of Rear Cover O-ring

1. Remove the cover screws **(6G)** and washers **(6H)** on the meter cover assembly **(3)** (opposite side from readout) and pull cover assembly straight away from the meter. Protect the rotor and cover assembly during this step.
2. Remove O-ring **(3D)** and replace it.
3. Assemble the meter cover assembly **(3)** to the meter housing **(1)**. Use care and slide the rotor and shaft assembly **(4)** into the bearing insert **(3B)**.
4. Secure cover assembly with screws **(6G)** and washers **(6H)**.

Replacement of Calibration Plug O-ring

1. Remove calibration plug cover **(6A)** by cutting and removing locking wire **(6J)**.

NOTE *Prior to removing the base plate **(5B)**, mark the location of the calibration plug stem **(5A)** to ensure the location of the plug does not change during disassembly and reassembly.*

2. Remove the base plate screws **(6F)** and pull the base plate **(5B)** and calibration plug **(5A)** out of the meter housing as an assembly.
3. Remove O-ring **(5C)** and replace it.
4. Assemble the base plate and calibration assembly into the meter housing. Make sure the location of the calibration stem is in the marked location.
5. Secure the base plate with screws **(6F)**.
6. Assemble calibration plug cover **(6A)** and lock it in place with wire **(6J)** and seal **(6B)**.

Refer to **INSTALLATION**.

Description	Kit No.	Items Included (quantity is 1 unless noted)
Rotor & Shaft Assembly		
Military (Ball Bearings)	LC01334-519	4A(2), 4B, 4C(2), 4D(2), 4E, 4F, 4G(2), 4H
Seal Kits		
Military (Viton)	LA01527-104	2E, 2F, 3D, 5C
Bearing Insert Kit		
Standard (SST)	KB01324-007	2C, 3C

Table 2. PL40A-1B1A-60 With NDH Service Kits (D01415-024)

Item	Quantity	Description
1	1	4 inch Meter, with 6 inch Couplings
2	1	Readout, NDH-BA40T
3	1	Skid, 6 inch Meter
4	1	Kit, Ground Rod Assembly
5	4	Screw, HHC, .500-13 UNC X 2.00
6	4	Washer, .500 Lock, Internal/External Tooth
7	2	Pin, Self Lock, Ø.19 X 1.00
8	4	Chain, #35 Bronze Sash X 9.00
9	4	Ring, Connector
10	2	Screw, Flat, #6-32 UNC X .38
11	2	Nut, Hex, #6-32 UNC
12	1	Nameplate, Ground Rod Storage
13	2	Screw, Round Slot, #4-40 UNC X .31
14	6	Nut, Hex, #4-40 UNC
15	1	Nameplate, Military
16	4	Screw, Round Slot, #4-40 UNC X .44

Table 3. 6 inch Portable Meter Assembly PL40A-1B1A-60 W/NDH (D02021-006)

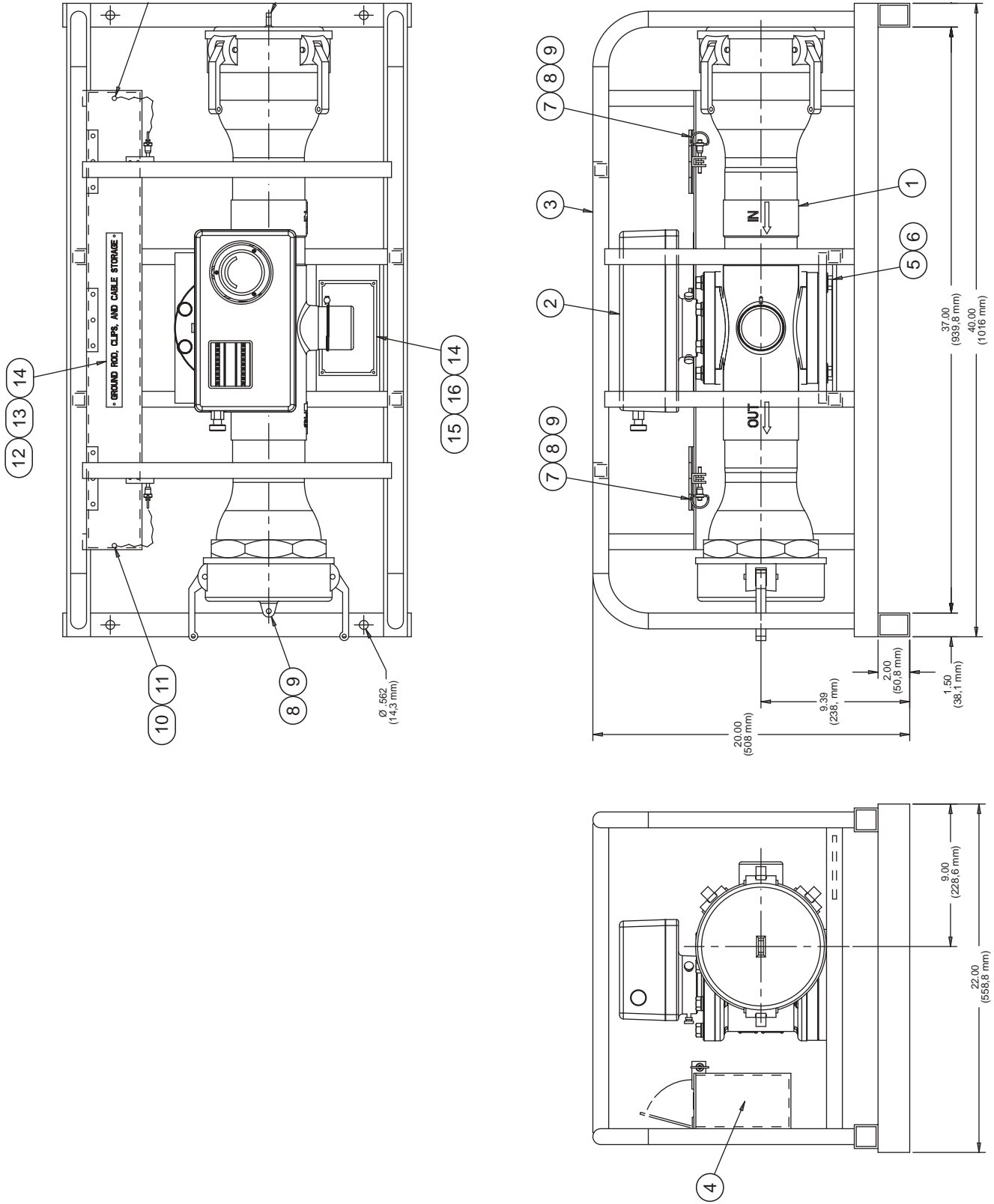

Figure 12. 6 inch Portable Meter Assembly (D0201-006)

Item	Quantity	Description	Torque
1	1	Weldment, PL40A-XXXX-60TTD6	-
2	1	ASM, Front Cover 4.00" Flow Meter	-
2A	1	Throttle Plate 4.00" Flow Meter	-
2B	1	Diaphragm, Flow Meter	-
2C	1	Bearing Insert 4.00" Flow Meter	-
2D	1	Housing Cover 4.00" Flow Meter	-
2E	1	O-Ring, 1.06 x .94 x .06	-
2F	1	O-Ring, 5.12 x 4.88 x .12	-
2G	4	SCR, MPH #6-32UNC x .50 Lg.	-
2H	As Req'd	Throttle Plate Spacer - .062" Thick	-
	As Req'd	Throttle Plate Spacer - .120" Thick	-
3	1	ASM, Rear Cover 4.00" Flow Meter	-
3A	1	Throttle Plate 4.00" Flow Meter	-
3B	1	Bearing Insert 4.00" Flow Meter	-
3C	1	Housing Cover 4.00" Flow Meter	-
3D	1	O-Ring, 5.12 x 4.88 x .12	-
3E	4	SCR, MPH #6-32UNC x .50 Lg.	-
3F	As Req'd	Throttle Plate Spacer - .062" Thick	-
	As Req'd	Throttle Plate Spacer - .120" Thick	-
4	1	ASM, Rotor & Shaft 4.00" Flow Meter	-
4A	2	Thrust Washer	-
4B	1	Spiral Pin .062 Dia. x .56 Lg.	-
4C	2	Spiral Pin .125 Dia. x 1.00 Lg.	-
4D	2	Ball Bearing 4.00" Flow Meter	-
4E	1	Rotor Cage, 4.00" Flow Meter	-
4F	1	Rotor Shaft 4.00" Flow Meter	-
4G	2	Flexloc Nut .375-24UNF	-
4H	1	Magnet Assembly	-
5	1	ASM, Calibration Plug 4.00" Flow Meter	-
5A	1	Calibration Plug 4.00" Flow Meter	-
5B	1	Base Plate 4.00" Flow Meter	-
5C	1	O-Ring, 1.62 x 1.44 x .09	-
5D	1	Hex Jam Nut .500-20UNF	-
6	1	Main Parts Group	-
6A	1	Calibration Plug Cover 4.00" Flow Meter	-
6B	1	Lead Seal	-
6C	1	Nameplate, 06-60 Flow Meter	-
6D	1	Nameplate, "CE" 15-60 Flow Meter	-
6E	8	SCR, Drive, #0 x .188 Lg.	-
6F	8	SCR, SHC, .250-20UNC x .88 Lg.	78 in•lbs (9 N•m)
6G	12	SCR, HHC, .500-13UNC x 1.50 Lg.	45 ft•lbs (61 N•m)
6H	12	Lock Washer .500 Mil. Spec.	-
6J	1	Wire, 20 Gage .035 Dia. x 12.00 Lg.	-
7	1	Coupling, 6.00" Male Cam and Groove	-
8	1	Coupling, 6.00" Female Cam and Groove	-
9	1	Plug, 6.00" Dust	-
10	1	Cap, 6.00" Dust	-

Table 3. PL40A-1B1A-60 w/ NDH Parts List and Screw Torque

Parts used in this assembly are per Oilgear specifications. Use only Oilgear parts to ensure the compatibility with the assembly requirements. When ordering replacement parts, be sure to include flow meter type and serial number, bulletin number and item number.

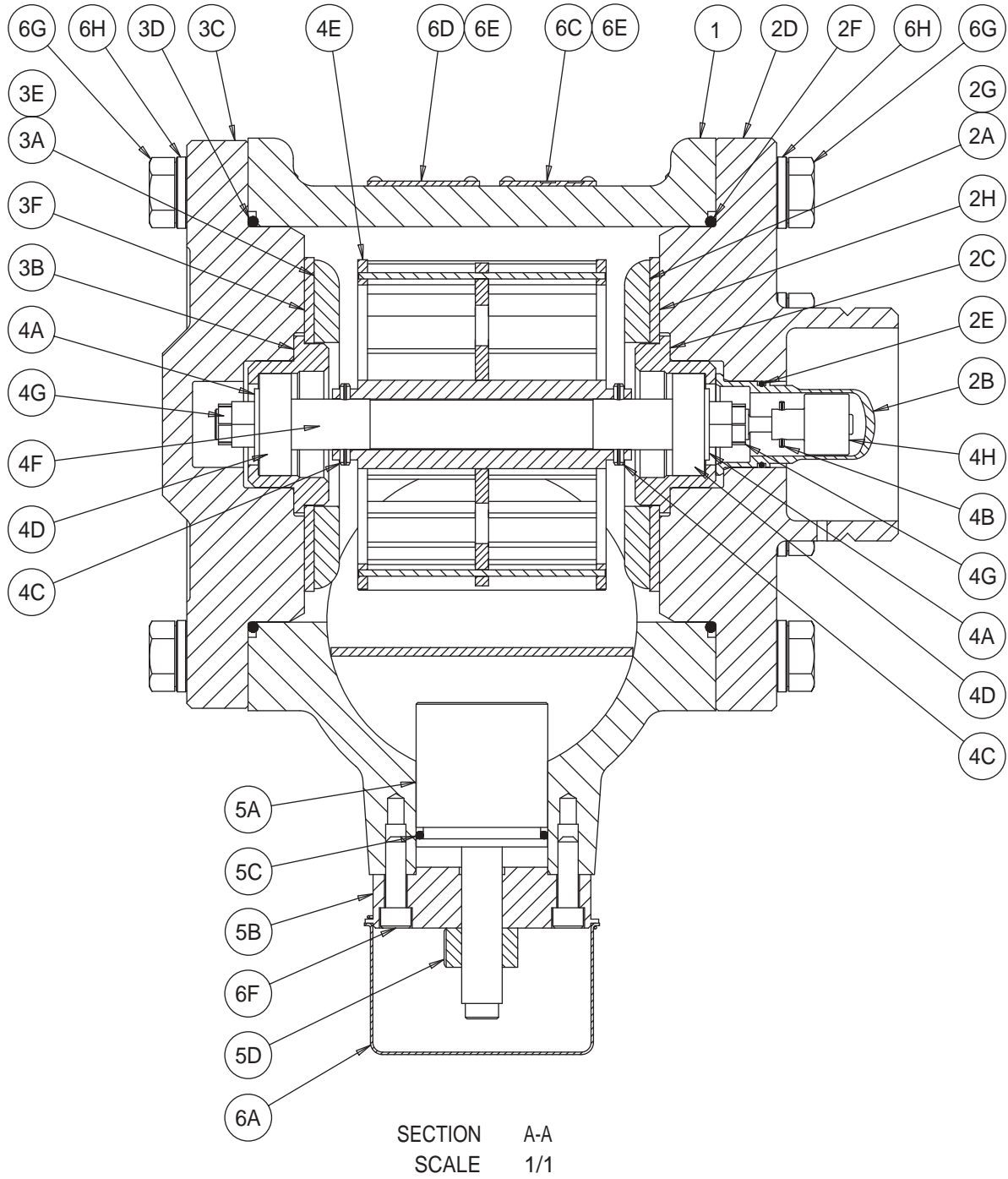

Figure 13. Parts drawing illustrating configuration of liquid flow meter.

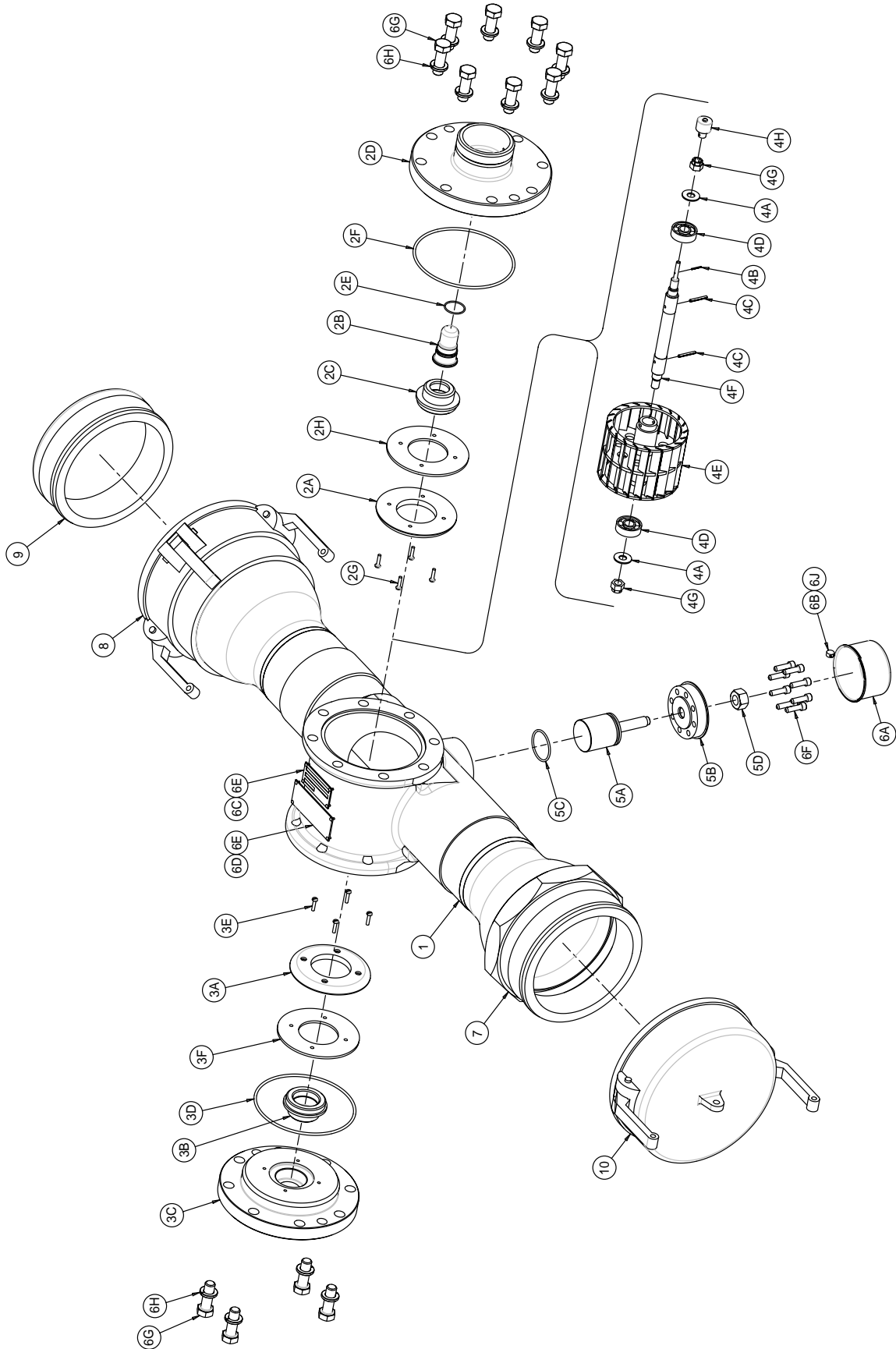

Figure 14. Parts Drawing, for ASM 6 inch Portable Meter Assembly (D01415-024 sheet 2 of 2)

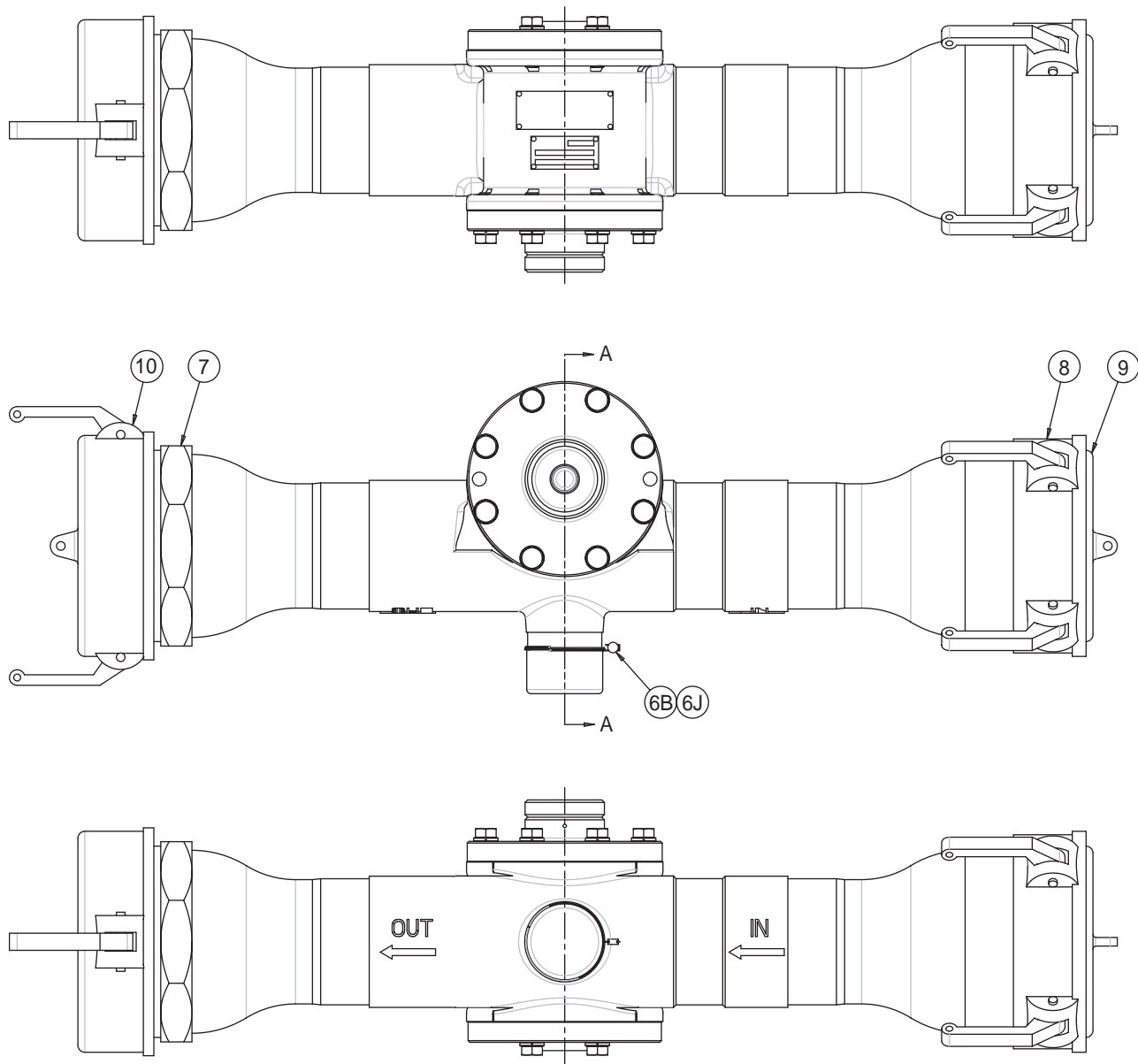

Figure 15. Parts Drawing, for ASM 6 inch Portable Meter Assembly (D01415-024 sheet 1 of 2)



THE OILGEAR COMPANY
2300 South 51st Street
Milwaukee, Wisconsin 53219
phone: 414/327-1700 fax: 414/327-0532
www.oilgear.com